

VFZ series - Aluminum worm gearboxes

Riduttori a vite senza fine in alluminio

Section **1**
Sezione 1



FEATURES

Caratteristiche

Hygienic design
Aluminum worm gearboxes

Riduttori a vite senza fine in alluminio

Type <i>Tipo</i>	Torque <i>Coppia</i>	Center distance <i>Interasse</i>	Input power <i>Potenza in entrata</i>	Hollow output shaft <i>Albero cavo in uscita</i>
Z30	21 Nm	30 mm	0.09 ÷ 0.18 kW	ø14 mm
Z45	41 Nm	45 mm	0.09 ÷ 0.37 kW	ø18 mm
Z50	72 Nm	50 mm	0.12 ÷ 0.75 kW	ø25 mm
Z63	147 Nm	63 mm	0.37 ÷ 1.8 kW	ø25 mm
Z85	347 Nm	85 mm	0.55 ÷ 4.0 kW	ø35 mm



This product is:

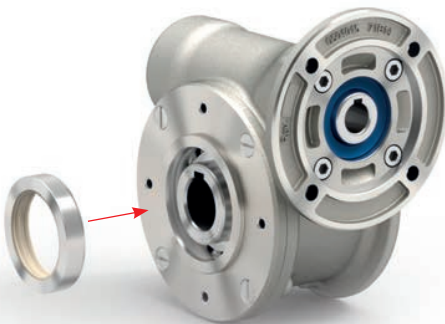

Twin viton seals with stainless steel shield.

Anelli di tenuta in viton con schermo protettivo in acciaio inox.

NTT™ stands for a special surface treatment which results in modified external properties of the mechanical parts with complex geometry. NTT™ treatment does not imply any kind of substance being applied on the surface.

NTT™ è uno speciale trattamento che come risultato ha la modifica delle proprietà superficiali delle parti meccaniche con geometria complessa.

Il trattamento NTT™ non implica l'applicazione di nessun tipo di sostanza sulla superficie.

FEATURES

Caratteristiche



Output shaft and hollow shaft in AISI 316L.

Mozzo e albero in uscita in AISI 316L.

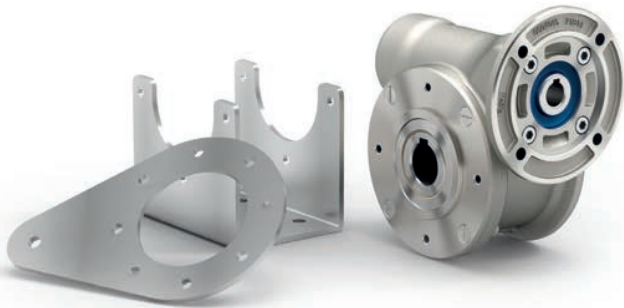

All stainless steel hardware.

Viteria in acciaio inox.



Nickel bronze worm gears CuSn12Ni (C91700) is centrifugally cast onto an iron hub for maximum strength and superior life.

Mozzo/corona in bronzo al Nickel CuSn12Ni (C91700) centrifugato; mozzo in acciaio per massima resistenza e durata superiore.































Housing with special smooth surfaces.

Cassa con finitura speciale liscia.

How to order

Codifica

P	Z50	UN	10	I
Type <i>Tipo</i>	Size <i>Grandezza</i>	Mounting <i>Montaggio</i>	Ratio <i>Rapporto</i>	Hub <i>Mozzo corona</i>
<p>P</p> 	<p>Z30 Z45 Z50 Z63 Z85</p>	<p>UN</p> 	 <p>See technical data table <i>Vedi tabelle dati tecnici</i></p>	<p>I</p>  <p>Standard</p> <p>Z30 -> $\varnothing 14$ Z45 -> $\varnothing 18$ Z50 -> $\varnothing 25$ Z63 -> $\varnothing 25$ Z85 -> $\varnothing 35$</p>
<p>M</p> 		<p>FC</p> 		
<p>B</p> 		<p>FL</p> 		
<p>R</p> 		<p>BR</p> 		
	<p>PA</p> 			
	<p>PV</p> 			
<p>Z</p> <p>Inch</p> <p>Z45 -> $\varnothing 0.750''$ Z50 -> $\varnothing 1.000''$ Z63 -> $\varnothing 1.125''$ Z85 -> $\varnothing 1.500''$</p>				

S	-Q	B	B3	-
Output shaft <i>Albero lento</i>	Motor size <i>Grandezza motore</i>	Terminal box position <i>Posizione morsetti</i>	Mounting position <i>Posizione di montaggio</i>	Coupling <i>Giunto</i>
<p>∅</p> 	 <p>IEC B5</p> <p>-A -> 56 B5 (∅120)</p>	<p>A</p> 	<p>B3</p> 	<p>-</p> <p>No indication Standard bore <i>Nessuna indicazione</i> Foro standard</p>
<p>S</p> 	<p>-B -> 63 B5 (∅140)</p> <p>-C -> 71 B5 (∅160)</p> <p>-D -> 80 B5 (∅200)</p> <p>-E -> 90 B5 (∅200)</p> <p>-F -> 100-112B5 (∅250)</p>	<p>B</p> 	<p>B8</p> 	<p>P</p> <p>Input bore reduced one size <i>Foro entrata ridotto di una entrata</i></p>
	<p>IEC B14</p> <p>-O -> 56 B14 (∅80)</p> <p>-P -> 63 B14 (∅90)</p> <p>-Q -> 71 B14 (∅105)</p> <p>-R -> 80 B14 (∅120)</p> <p>-T -> 90 B14 (∅140)</p> <p>-U -> 100-112B14 (∅160)</p>	<p>C</p> 	<p>B6</p> 	<p>Q</p> <p>Input bore reduced two size <i>Foro entrata ridotto di due misure</i></p>
	<p>NEMA</p> <p>-W -> 56C (∅6.5")</p> <p>-X -> 143/5TC (∅6.5")</p> <p>-Y -> 182/4TC (∅8.88")</p> <p>AA -> 213/5TC (∅8.88")</p>	<p>D</p> 	<p>B7</p> 	<p>With coupling</p> 
<p>-M</p> 			<p>V5</p> 	<p>A -> 9mm</p> <p>B -> 11mm</p> <p>C -> 14mm</p> <p>D -> 19mm</p> <p>E -> 24mm</p> <p>F -> 28mm</p>
<p>-0</p> 			<p>V6</p> 	<p>0</p> <p>Without coupling <i>Senza giunto</i></p> 

Useful formulas

Formule utili

Required power - Potenza richiesta

Lifting - Sollevamento

$$P_{[kW]} = \frac{M_{[Kg]} \cdot g_{[9.81]} \cdot v_{[m/s]}}{1000}$$

Rotation - Rotazione

$$P_{[kW]} = \frac{M_{[Nm]} \cdot n_{[rpm]}}{9550}$$

Linear movement - Traslazione

$$P_{[kW]} = \frac{F_{[N]} \cdot v_{[m/s]}}{1000}$$

Torque - Coppia

$$M_{[Nm]} = \frac{9550 \cdot P_{[kW]}}{n_{[rpm]}}$$

$$M_{[lb\ in]} = \frac{63030 \cdot P_{[HP]}}{n_{[rpm]}}$$

Radial loads - Carichi radiali

Radial load generated by external transmissions keyed onto input and/or output shafts.

Forza radiale generata da organi di trasmissione calettati sugli alberi di ingresso e/o uscita.

$$F_{R[N]} = \frac{M_{[Nm]} \cdot 2000}{d_{[mm]}} \cdot f_k$$

$$F_{R[N]} = \frac{M_{[lb\ in]} \cdot 8.9}{d_{[in]}} \cdot f_k$$

M: Output torque - Momento torcente

d: Diam. of driving element - Diametro primitivo

f_k: Factor - Coefficiente di trasformazione

1.15: Gearwheels - Ingranaggi

1.25: Chain sprockets - Catena

1.75: Narrow v-belt pulley - Cinghia Trapezoidale

2.50: Flat-belt pulley - Cinghia piatta

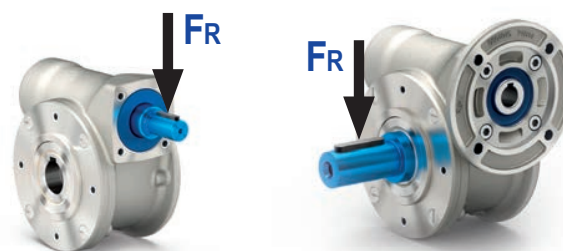

If your application requires higher radial loads, contact our technical office. Higher loads may be possible.

Nel caso la vostra applicazione richieda carichi radiali superiori consultare il nostro ufficio tecnico, valori maggiori possono essere accettati.

How to select a gearbox

Come selezionare un riduttore

A Select required torque (according to service factor)

Seleziona la coppia desiderata (comprensiva del fattore di servizio)

B Select output speed

Seleziona la velocità in uscita

C Select gear ratio in the line corresponding to the chosen motor power

Sulla riga corrispondente alla motorizzazione prescelta si può rilevare il rapporto di riduzione

D Select motor flange available (if requested)

Scegli la flangia disponibile (se richiesta)

Gear size
Grandezza riduttore

Z30

Ratio
Rapporto

21

Transmitted torque
Momento torcente trasmesso

21 Nm

Nominal power
Potenza nominale

Flange code
Codice flangia

Dynamic efficiency
Rendimento dinamico

Input speed
Velocità in entrata

Hygienic design Aluminum worm gearboxes

Riduttori a vite senza fine in alluminio

Output speed n_2 [min ⁻¹]	Ratio i	Motor power P_{1M} [kW]	Output torque M_{2M} [Nm]	Service factor f.s	Nominal power P_{1R} [kW]	Nominal torque M_{2R} [Nm]	B5 motor flanges		B14 motor flanges		Dynamic efficiency RD	Tooth module [mm]	Ratio code
							-A 56	-B 63	-O 56	-P 63			
280	5	0.18	5	3.3	0.60	17	B		B-C		82	1.26	09
200	7	0.18	7	2.4	0.44	17	B		B-C		80	1.44	01
140	10	0.18	10	1.8	0.32	17	B		B-C		78	1.44	02
93	15	0.18	13	1.4	0.25	19	B		B-C		73	1.44	03
70	20	0.18	17	1.1	0.20	19	B		B-C		70	1.09	04
47	30	0.12	15	1.4	0.17	21	B		B-C		62	1.44	05
35	40	0.12	19	1.1	0.13	20	B		B-C		57	1.09	06
23	61	0.09	19	1.1	0.10	20	B		B-C		50	0.72	07
17.5	80	0.09	16	1.0	0.06	16	B		B-C		48	0.56	08

B Output speed
Velocità in uscita

Motor power
Potenza motore

Service factor
Fattore di servizio

A Nominal torque
Momento torcente nominale

Nominal module
Modulo nominale

Notes
Note

Type of load and starts per hour Tipo di carico e avviamenti per ora	Oper. hours per day Ore di funz. giorn.	Oper. hours per day			
		<2h	2÷8h	8÷16h	
Continuous or intermittent application with start / hour Applicazione continua o intermittente con numero operazioni/ora	≤ 10	Uniform - <i>Uniforme</i>	0.9	1	1.25
		Moderate - <i>Moderato</i>	1	1.25	1.5
		Heavy - <i>Forte</i>	1.25	1.5	1.75
Intermittent application with start / hour Applicazione intermittente con numero operazioni/ora	> 10	Uniform - <i>Uniforme</i>	1.25	1.5	1.75
		Moderate - <i>Moderato</i>	1.5	1.75	2
		Heavy - <i>Forte</i>	1.75	2	2.25

D Motor flange available
Flange disponibili

B) Mounting with reduction bushing
Montaggio con boccola di riduzione

C) Motor flange holes position/terminal box position
Posizione fori flangia/basetta motore

B) Available without reduction bushing
Disponibile anche senza boccola



Z30

21 Nm

Hygienic design Aluminum worm gearboxes

Riduttori a vite senza fine in alluminio

Input speed (n_1) = 1400 min⁻¹

Output speed n_2 [min ⁻¹]	Ratio i	Motor power P_{1M} [kW]	Output torque M_{2M} [Nm]	Service factor f.s	Nominal power P_{1R} [kW]	Nominal torque M_{2R} [Nm]	B5 motor flanges		B14 motor flanges		Dynamic efficiency RD	Tooth module  [mm]	Ratio code 
							-A 56	-B 63	-O 56	-P 63			
280	5	0.18	5	3.3	0.60	17	B		B-C		82	1.26	09
200	7	0.18	7	2.4	0.44	17	B		B-C		80	1.44	01
140	10	0.18	10	1.8	0.32	17	B		B-C		78	1.44	02
93	15	0.18	13	1.4	0.25	19	B		B-C		73	1.44	03
70	20	0.18	17	1.1	0.20	19	B		B-C		70	1.09	04
47	30	0.12	15	1.4	0.17	21	B		B-C		62	1.44	05
35	40	0.12	19	1.1	0.13	20	B		B-C		57	1.09	06
23	61	0.09	19	1.1	0.10	20	B		B-C		50	0.72	07
17.5	80	0.09	16	1.0	0.06	16	B		B-C		48	0.56	08

Motor flanges available
Flange motore disponibili

 B) Supplied with reduction bushing
Fornito con bussola di riduzione

B) Available on request without reduction bushing
Disponibile a richiesta senza bussola di riduzione

 C) Motor flange holes position
Posizione fori flangia motore

Lubrication

Lubrificazione

Unit Z30 is supplied with synthetic oil to assure long life lubrication.

Food grade oil is available on request.

See Table 1 for lubrication and recommended quantity.

See Table 2 for possible radial and axial loads on the gearbox.

Il riduttore tipo Z30 viene fornito con olio sintetico e lubrificazione tipo "long life".

Disponibile a richiesta olio alimentare.

Vedi Tabella 1 per oli e quantità consigliati.

Vedi Tabella 2 per i carichi radiali e assiali applicabili al riduttore.

Oil quantity for
all positions:
0.03Lt.

Quantità olio per tutte
le posizioni: 0.03Lt.

Agip
Telium VSF 320

Shell
Omala S4 WE 320

Tab. 1

Radial and axial loads

Carichi radiali e assiali

Output shaft

Albero di uscita

n_2 [min ⁻¹]	F_A [N]	F_R [N]
200	120	600
150	140	700
100	160	800
75	180	900
50	200	1000
25	250	1250
15	280	1400

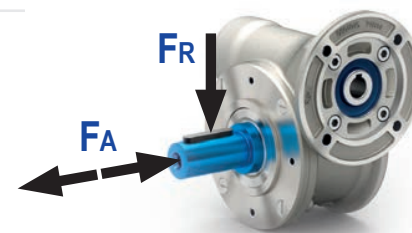

Input shaft

Albero in entrata

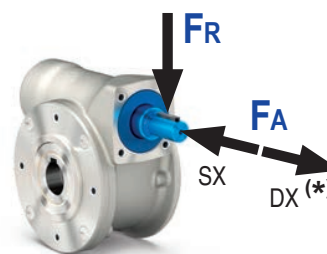

n_1 [min ⁻¹]	F_A [N]	F_R [N]
1400	20	100

* Strong axial loads in the DX direction are not allowed.

* Non sono consentiti forti carichi assiali con direzione DX

Tab. 2

21 Nm

Z30

PZ30UN.. Basic gearbox
Riduttore base

Gearbox weight
peso riduttore **1.25 kg**

M. flanges	Kit code	øF	A
56B5	KZ304041	120	62
63B5	KZ304042	140	63
56B14	KZ304046	80	62
63B14	KZ304045	90	63

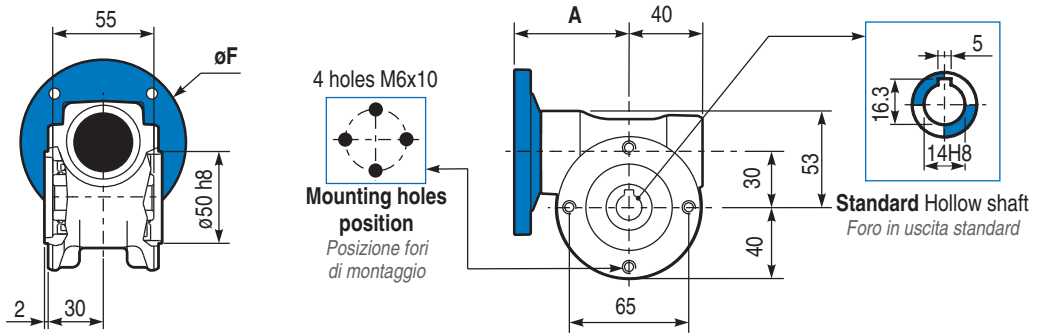

PZ30PA.. Feet
Piedini

kit cod. KIZ309022

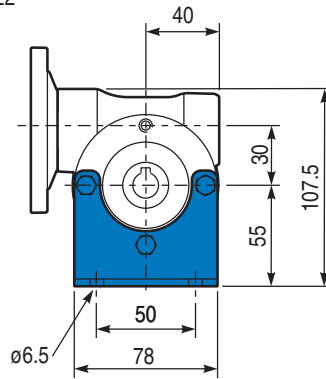
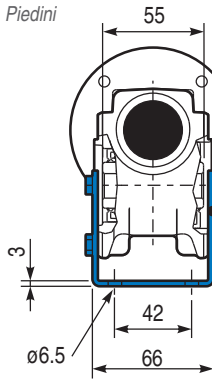

PZ30PV.. Feet
Piedini

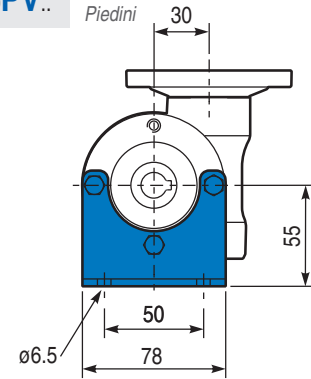

PZ30FC.. Output flange
Flangia uscita

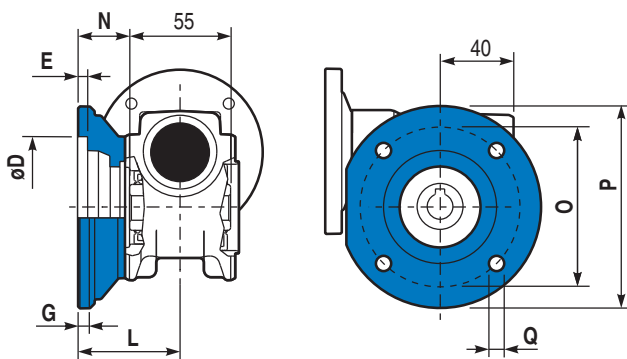

PZ30BR.. Reaction arm
Braccio di reazione

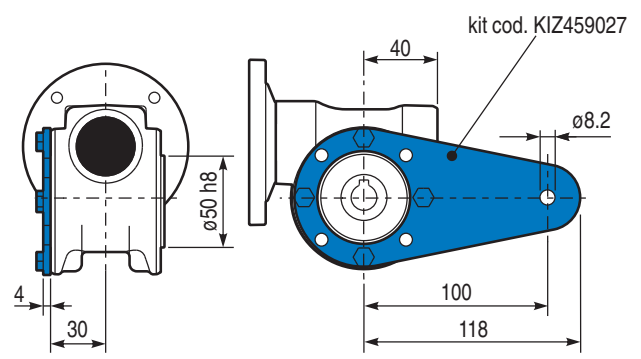

Type	øD	E	G	L	N	O	P	Q	Kit code
FC	50 ^{+0.15} / _{-0.05}	6	6	50.5	23	68	80	7	KZ309010
FL	60 ^{+0.15} / _{-0.05}	6	6	55.5	28	87	110	8.5	KZ459010

PZ30..S.. Single output shaft
Albero semplice in uscita

kit cod. KI0305028

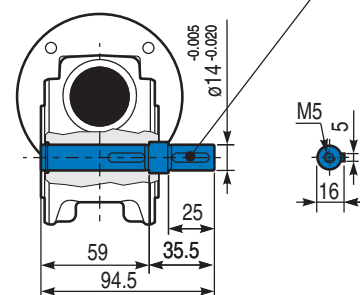

RZ30UN.. Input shaft
Albero in entrata

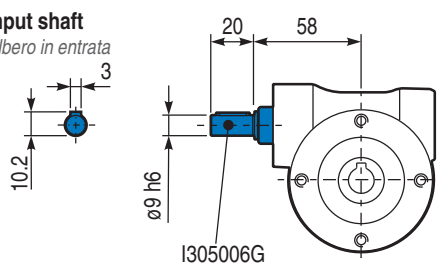



Z45

41 Nm

Hygienic design Aluminum worm gearboxes

Riduttori a vite senza fine in alluminio

Input speed (n_1) = 1400 min⁻¹

Output speed n_2 [min ⁻¹]	Ratio i	Motor power P_{1M} [kW]	Output torque M_{2M} [Nm]	Service factor f.s	Nominal power P_{1R} [kW]	Nominal torque M_{2R} [Nm]	B5 motor flanges		B14 motor flanges			Dynamic efficiency RD	Tooth module  [mm]	Ratio code 
							-B 63	-C 71	-O 56	-P 63	-Q 71			
200	7	0.37	14	2.2	0.80	30	B		B-C	B-C		80	2.2	01
140	10	0.37	20	1.5	0.57	30	B		B-C	B-C		79	2.2	02
100	14	0.37	27	1.1	0.41	30	B		B-C	B-C		77	2.4	03
67	21	0.37	36	1.2	0.43	41	B		B-C	B-C		67	1.6	04
50	28	0.25	31	1.3	0.33	41	B		B-C	B-C		65	2.5	05
38	37	0.25	40	1.0	0.26	41	B		B-C	B-C		63	1.8	06
30	46	0.25	46	0.9	0.22	41	B		B-C	B-C		59	1.5	07
23	60	0.18	41	1.0	0.18	41	B		B-C	B-C		56	1.2	08
20	70	0.12	31	1.0	0.12	30	B		B-C	B-C		54	1.0	09
13.7	102	0.09	31	1.0	0.09	29	B		B-C	B-C		49	0.72	10

Motor flanges available
Flange motore disponibili

 B) Supplied with reduction bushing
Fornito con bussola di riduzione

B) Available on request without reduction bushing
Disponibile a richiesta senza bussola di riduzione

 C) Motor flange holes position
Posizione fori flangia motore

Lubrication

Lubrificazione

Unit Z45 is supplied with synthetic oil to assure long life lubrication.
Food grade oil is available on request.

See Table 1 for lubrication and recommended quantity.

See Table 2 for possible radial and axial loads on the gearbox.

Il riduttore tipo Z45 viene fornito con olio sintetico e lubrificazione tipo "long life".

Disponibile a richiesta olio alimentare.

Vedi Tabella 1 per oli e quantità consigliati.

Vedi Tabella 2 per i carichi radiali e assiali applicabili al riduttore.

Oil quantity for all positions: 0.09Lt.	Agip Telium VSF 320	Shell Omala S4 WE 320
Quantità olio per tutte le posizioni: 0.09Lt.		

Tab. 1

Radial and axial loads

Carichi radiali e assiali

Output shaft

Albero di uscita

n_2 [min ⁻¹]	F_A [N]	F_R [N]
200	180	900
150	200	1000
100	220	1100
75	240	1200
50	260	1400
25	300	1800
15	400	2000

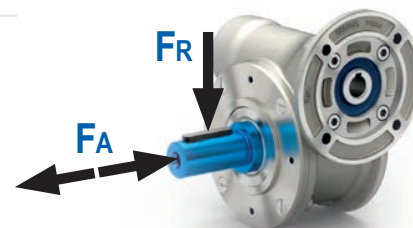

Input shaft

Albero in entrata

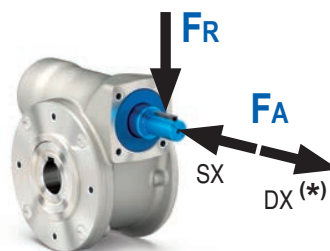

n_1 [min ⁻¹]	F_A [N]	F_R [N]
1400	42	210

* Strong axial loads in the DX direction are not allowed.

* Non sono consentiti forti carichi assiali con direzione DX

Tab. 2

41 Nm

Z45

PZ45UN.. Basic gearbox
Riduttore base

Gearbox weight
peso riduttore 2.50 kg

M. flanges	Kit code	øF	A
63B5	KZ454041	138	74
71B5	KZ454042	160	71.5
56B14	KZ454049	80	71.5
63B14	KZ454047	90	74
71B14	KZ454045	105	71.5

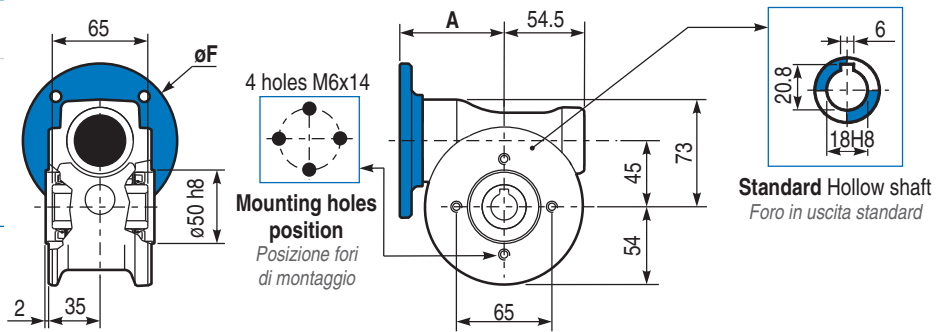

PZ45PA.. Feet
Piedini

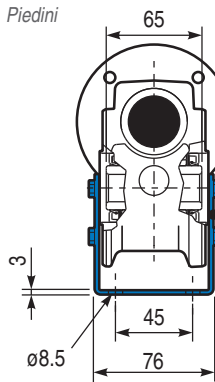

PZ45PV.. Feet
Piedini

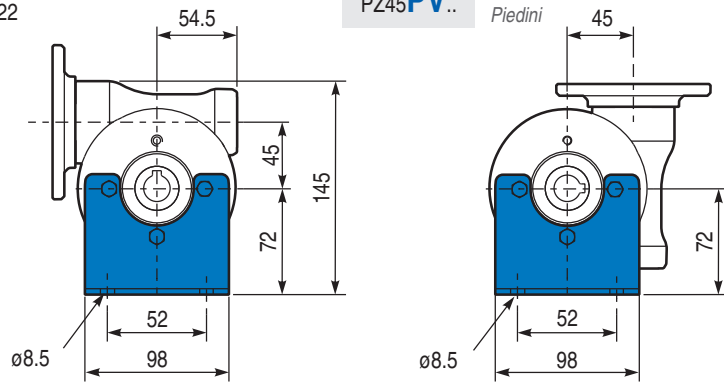

PZ45FC.. Output flange
Flangia uscita

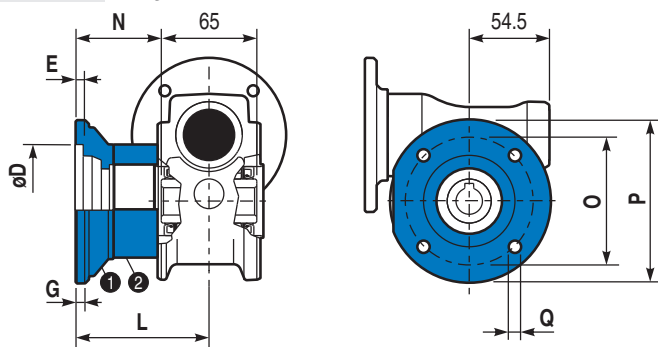

Type	øD	E	G	L	N	O	P	Q	Kit code
FC	60 ^{+0.15} / _{+0.05}	9	9	60.5	28	87	110	8.5	1 KZ459010 2 -
FL	60 ^{+0.15} / _{+0.05}	9	9	90.5	58	87	110	8.5	1 KZ459010 2 KZ450200

PZ45BR.. Reaction arm
Braccio di reazione

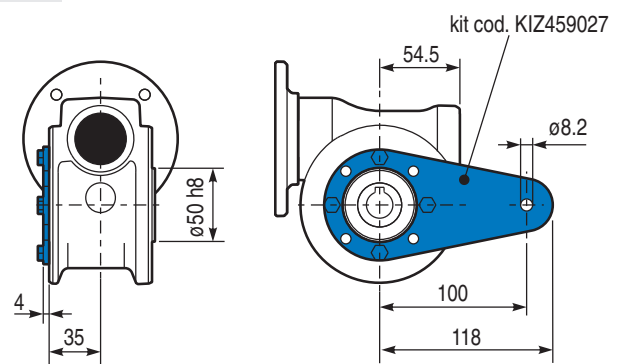

PZ45.S.. Single output shaft
Albero semplice in uscita

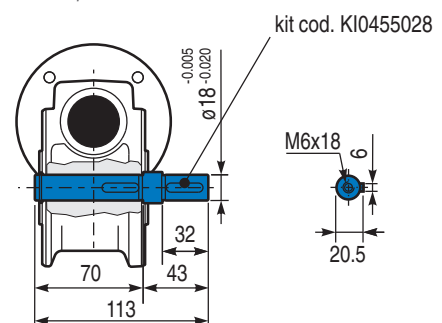

RZ45UN.. Input shaft
Albero in entrata

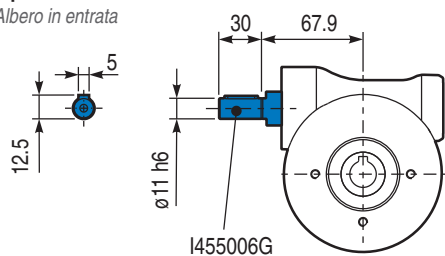



Z50

72
Nm

Hygienic design Aluminum worm gearboxes

Riduttori a vite senza fine in alluminio

Input speed (n_1) = 1400 min⁻¹

Output speed n_2 [min ⁻¹]	Ratio i	Motor power P_{1M} [kW]	Output torque M_{2M} [Nm]	Service factor f.s	Nominal power P_{1R} [kW]	Nominal torque M_{2R} [Nm]	B5 motor flanges			B14 motor flanges			Dynamic efficiency RD	Tooth module  [mm]	Ratio code 	
							-B 63	-C 71	-D 80	-O 56	-P 63	-Q 71				-R 80
200	7	0.75	29	1.9	1.5	57	B	B			B-C	B		82	2.5	01
140	10	0.75	41	1.5	1.1	62	B	B			B-C	B		80	2.4	02
100	14	0.75	57	1.2	0.90	68	B	B			B-C	B		79	2.6	03
78	18	0.55	51	1.2	0.67	62	B	B			B-C	B		75	2.0	04
54	26	0.55	67	1.0	0.54	66	B	B			B-C	B		69	2.7	05
47	30	0.55	79	0.9	0.50	72	B	B			B-C	B		70	2.5	12
39	36	0.37	63	1.2	0.43	72	B				B-C	B-C		69	2.1	06
33	43	0.37	72	1.0	0.35	68	B				B-C	B-C		66	1.8	07
28	50	0.25	53	1.2	0.31	66	B				B-C	B-C		62	1.5	13
23	60	0.25	59	1.0	0.26	62	B				B-C	B-C		58	1.3	08
21	68	0.25	66	0.9	0.22	58	B				B-C	B-C		57	1.2	09
17.5	80	0.18	53	1.1	0.19	57	B				B-C	B-C		54	1.0	10
14	100	0.12	41	1.3	0.15	51	B				B-C	B-C		50	0.8	11

Motor flanges available
Flange motore disponibili



B) Supplied with reduction bushing
Fornito con bussola di riduzione



B) Available on request without reduction bushing
Disponibile a richiesta senza bussola di riduzione



C) Motor flange holes position
Posizione fori flangia motore

Lubrication

Lubrificazione

Unit Z50 is supplied with synthetic oil to assure long life lubrication.
Food grade oil is available on request.

See Table 1 for lubrication and recommended quantity.

See Table 2 for possible radial and axial loads on the gearbox.

Il riduttore tipo Z50 viene fornito con olio sintetico e lubrificazione tipo "long life".

Disponibile a richiesta olio alimentare.

Vedi Tabella 1 per oli e quantità consigliati.

Vedi Tabella 2 per i carichi radiali e assiali applicabili al riduttore.

Oil quantity for
all positions:
0.14Lt.

Quantità olio per tutte
le posizioni: 0.14Lt.

Agip
Telium VSF 320

Shell
Omala S4 WE 320

Tab. 1

Radial and axial loads

Carichi radiali e assiali

Output shaft

Albero di uscita

n_2 [min ⁻¹]	F_A [N]	F_R [N]
200	240	1200
150	280	1400
100	300	1500
75	340	1700
50	380	1900
25	480	2500
15	560	2800

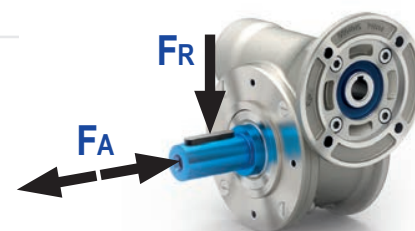

Input shaft

Albero in entrata

n_1 [min ⁻¹]	F_A [N]	F_R [N]
1400	76	380

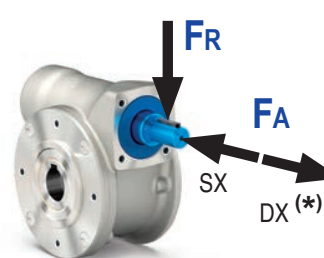

* Strong axial loads in the DX direction are not allowed.

* Non sono consentiti forti carichi assiali con direzione DX

Tab. 2

72 Nm

Z50

PZ50UN.. Basic gearbox
Riduttore base

Gearbox weight
peso riduttore **3.70 kg**

M. flanges	Kit code	øF	A
63B5	KZ504041	138	78.5
71B5	KZ504042	160	76
80B5	KZ504043	200	76.5
56B14	KZ504049	80	76
63B14	KZ504047	90	78.5
71B14	KZ504045	105	76
80B14	KZ504046	120	76.5

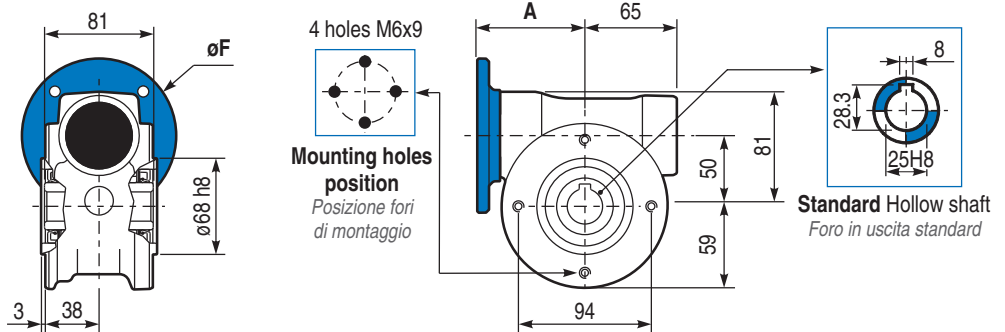

PZ50PA.. Feet
Piedini

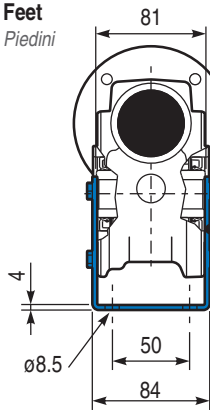

kit cod. KIZ509022

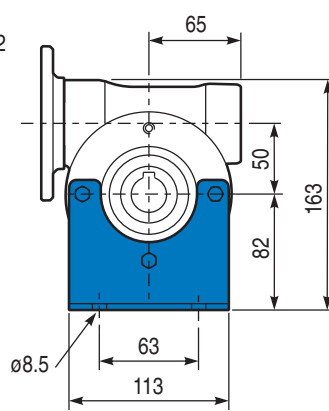

PZ50PV.. Feet
Piedini

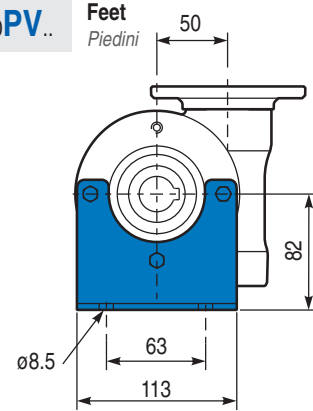

PZ50FC.. Output flange
Flangia uscita

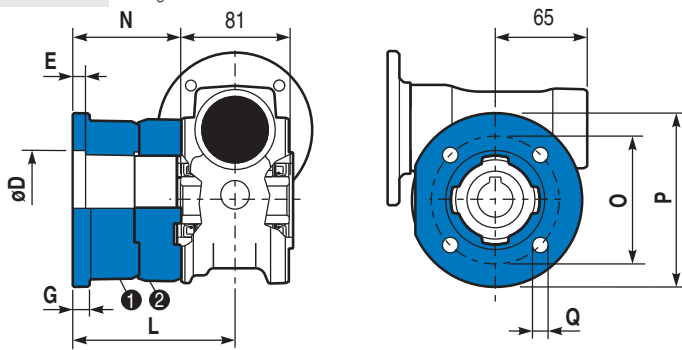

Type	øD	E	G	L	N	O	P	Q	Kit code
FC	70 ^{+0.20} / _{+0.15}	9	12	85	44.5	90	123	10.5	① KZ509010 ② -
FL	70 ^{+0.20} / _{+0.15}	9	12	114.5	74	90	123	10.5	① KZ509010 ② KZ500200

PZ50BR.. Reaction arm
Braccio di reazione

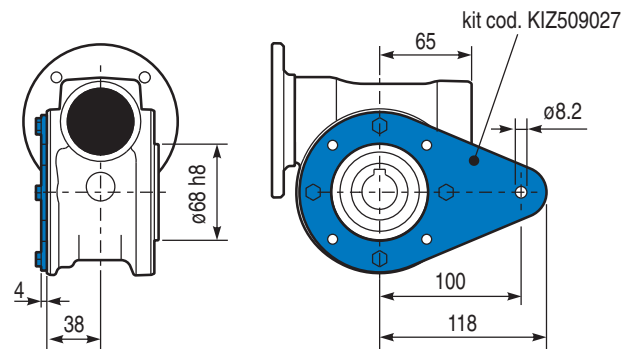

kit cod. KIZ509027

PZ50..S.. Single output shaft
Albero semplice in uscita

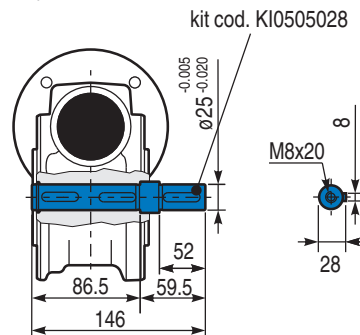

kit cod. KI0505028

RZ50UN.. Input shaft
Albero in entrata

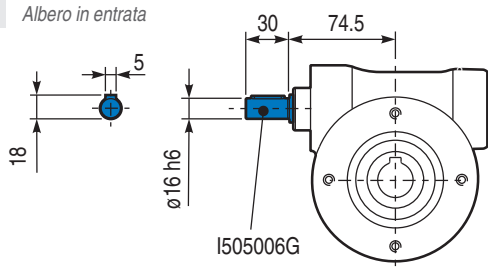

I505006G



Z63

147 Nm

Hygienic design Aluminum worm gearboxes

Riduttori a vite senza fine in alluminio

Input speed (n_1) = 1400 min⁻¹

Output speed n_2 [min ⁻¹]	Ratio i	Motor power P_{1M} [kW]	Output torque M_{2M} [Nm]	Service factor f.s	Nominal power P_{1R} [kW]	Nominal torque M_{2R} [Nm]	B5 motor flanges				B14 motor flanges			Dynamic efficiency RD	Tooth module  [mm]	Ratio code 
							-B 63	-C 71	-D 80	-E 90	-Q 71	-R 80	-T 90			
200	7	1.8	71	1.8	3.2	125		B	B		B-C	B-C		83	3.1	01
140	10	1.8	99	1.4	2.4	134		B	B		B-C	B-C		81	3.1	02
93	15	1.5	121	1.1	1.7	138		B	B		B-C	B-C		79	3.1	03
74	19	1.1	111	1.2	1.4	138		B	B		B-C	B-C		78	2.6	04
58	24	1.1	135	1.0	1.2	142		B	B		B-C	B-C		75	2.0	05
47	30	1.1	167	0.9	0.96	146		B	B		B-C	B-C		74	3.2	06
39	36	0.75	125	1.2	0.88	147		B	B		B-C	B-C		68	2.7	07
35	40	0.75	135	1.0	0.78	140		B	B		B-C	B-C		66	2.5	13
31	45	0.55	111	1.2	0.67	135	B	B			B-C	C		66	2.1	08
23	60	0.55	140	0.9	0.51	130	B	B			B-C	C		62	1.6	12
21	67	0.55	151	0.8	0.45	124	B	B			B-C	C		60	1.5	09
17.5	80	0.37	115	1.0	0.38	119	B	B			B-C	C		57	1.3	10
14.9	94	0.37	123	1.0	0.36	119	B	B			B-C	C		52	1.1	11

Motor flanges available
Flange motore disponibili

 B) Supplied with reduction bushing
Fornito con bussola di riduzione

B) Available on request without reduction bushing
Disponibile a richiesta senza bussola di riduzione

 C) Motor flange holes position
Posizione fori flangia motore

Lubrication

Lubrificazione

Unit Z63 is supplied with synthetic oil to assure long life lubrication.
Food grade oil is available on request.

See Table 1 for lubrication and recommended quantity.

See Table 2 for possible radial and axial loads on the gearbox.

Il riduttore tipo Z63 viene fornito con olio sintetico e lubrificazione tipo "long life".

Disponibile a richiesta olio alimentare.

Vedi Tabella 1 per oli e quantità consigliati.

Vedi Tabella 2 per i carichi radiali e assiali applicabili al riduttore.

Radial and axial loads

Carichi radiali e assiali

Output shaft

Albero di uscita

n_2 [min ⁻¹]	F_A [N]	F_R [N]
200	360	1800
150	400	2000
100	460	2300
75	500	2500
50	600	3000
25	700	3800
15	800	4000

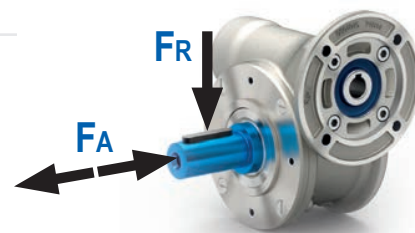

Input shaft

Albero in entrata

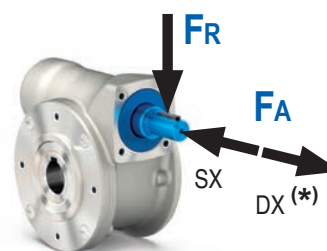

n_1 [min ⁻¹]	F_A [N]	F_R [N]
1400	90	450

* Strong axial loads in the DX direction are not allowed.

* Non sono consentiti forti carichi assiali con direzione DX

Oil quantity for
all positions:
0.40Lt.

Quantità olio per tutte
le posizioni: 0.40Lt.

Agip
Telium VSF 320

Shell
Omala S4 WE 320

Tab. 1

Tab. 2

147 Nm

Z63

PZ63UN.. Basic gearbox
Riduttore base

Gearbox weight
peso riduttore **6.70 kg**

M. flanges	Kit code	øF	A
63B5	KZ634041	140	99.5
71B5	KZ634042	160	97.5
80/90B5	KZ634043	200	99.5
71B14	KZ634047	105	97.5
80B14	KZ634046	120	99.5
90B14	KZ634041	140	99.5

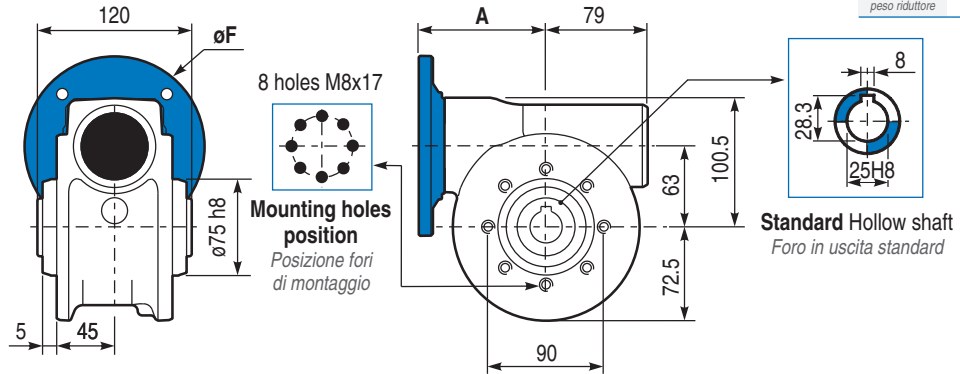

PZ63PA.. Feet
Piedini

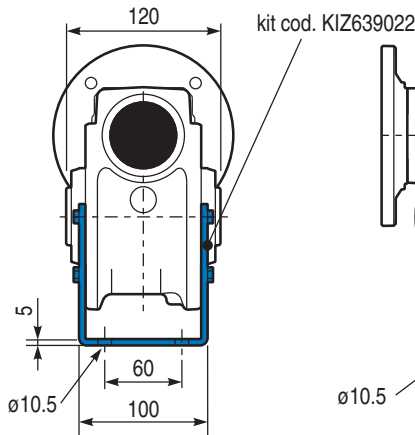

PZ63PV.. Feet
Piedini

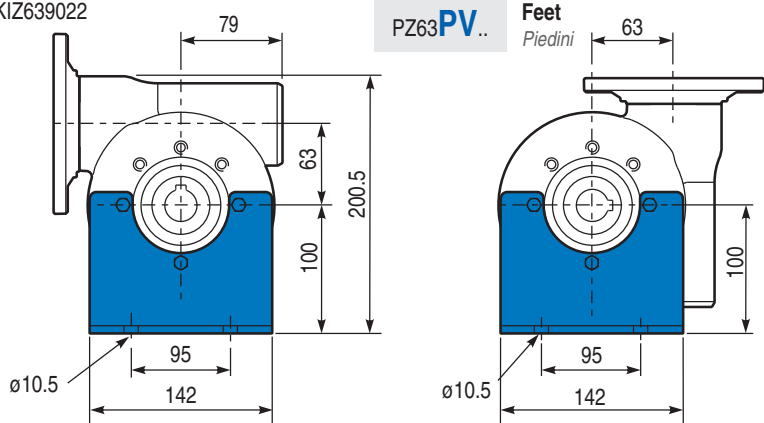

PZ63FC.. Output flange
Flangia uscita

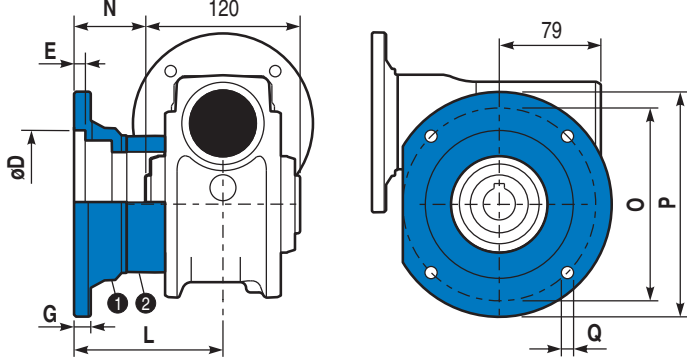

Type	øD	E	G	L	N	O	P	Q	Kit code
FC	115 ^{+0.20} / _{-0.15}	7	13	86	26	150	175	11	① KZ639010 ② -
FL	115 ^{+0.20} / _{-0.15}	7	13	116	56	150	175	11	① KZ639010 ② KZ630200

PZ63BR.. Reaction arm
Braccio di reazione

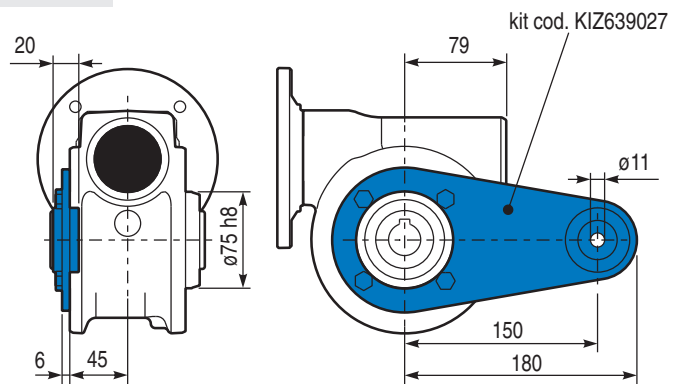

RZ63UN.. Input shaft
Albero in entrata

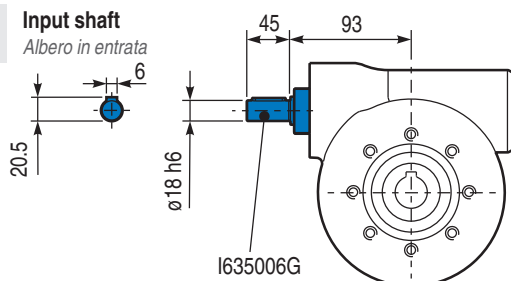

PZ63..S.. Single output shaft
Albero semplice in uscita

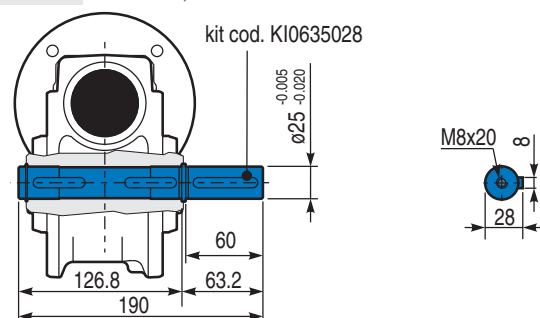



Z85

347 Nm

Hygienic design Aluminum worm gearboxes

Riduttori a vite senza fine in alluminio

Input speed (n_1) = 1400 min⁻¹

Output speed n_2 [min ⁻¹]	Ratio i	Motor power P_{1M} [kW]	Output torque M_{2M} [Nm]	Service factor f.s	Nominal power P_{1R} [kW]	Nominal torque M_{2R} [Nm]	B5 motor flanges			B14 motor flanges			Dynamic efficiency RD	Tooth module  [mm]	Ratio code 	
							-C 71	-D 80	-E 90	-F 100 112	-R 80	-T 90				-U 100 112
200	7	4.0	168	1.5	6.1	257		B	B		B	B		88	4.23	01
140	10	4.0	218	1.3	5.2	284		B	B		B	B		80	4.2	02
100	14	3.0	223	1.4	4.1	305		B	B		B	B		78	4.5	03
70	20	2.2	237	1.2	2.7	294		B	B		B	B		79	3.4	04
64	22	2.2	258	1.1	2.5	294		B	B		B	B		78	3.1	05
50	28	2.2	315	1.1	2.4	347		B	B		B	B		75	4.7	06
37	38	1.5	276	1.2	1.8	336	B	B			B			71	3.5	07
30	46	1.5	320	1.0	1.5	326	B	B			B			68	3.1	08
27	52	1.1	258	1.1	1.2	289	B	B			B			66	2.7	09
21	67	1.1	327	0.9	0.97	289	B	B			B			65	2.1	10
18.9	74	0.75	220	1.2	0.91	268	B	B			B			58	1.9	11
14.6	96	0.55	191	1.3	0.70	242	B	B			B			53	1.5	12

Motor flanges available
Flange motore disponibili

 B) Supplied with reduction bushing
Fornito con bussola di riduzione

B) Available on request without reduction bushing
Disponibile a richiesta senza bussola di riduzione

 C) Motor flange holes position
Posizione fori flangia motore

Lubrication

Lubrificazione

Unit Z85 is supplied with synthetic oil to assure long life lubrication.

Food grade oil is available on request.

See Table 1 for lubrication and recommended quantity.

See Table 2 for possible radial and axial loads on the gearbox.

Il riduttore tipo Z85 viene fornito con olio sintetico e lubrificazione tipo "long life".

Disponibile a richiesta olio alimentare.

Vedi Tabella 1 per oli e quantità consigliati.

Vedi Tabella 2 per i carichi radiali e assiali applicabili al riduttore.

Radial and axial loads

Carichi radiali e assiali

Output shaft

Albero di uscita

n_2 [min ⁻¹]	F_A [N]	F_R [N]
200	500	2500
150	580	2900
100	600	3000
75	700	3500
50	800	4000
25	1000	5000
15	1160	5800

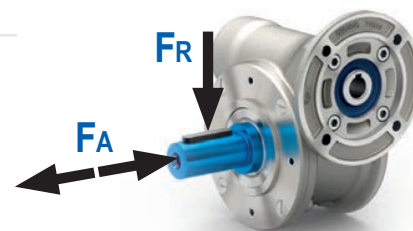

Input shaft

Albero in entrata

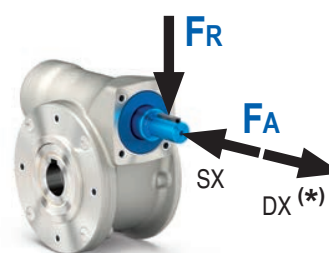

n_1 [min ⁻¹]	F_A [N]	F_R [N]
1400	160	809

* Strong axial loads in the DX direction are not allowed.

* Non sono consentiti forti carichi assiali con direzione DX

Oil quantity for
all positions:
1.20Lt.

Agip
Telium VSF 320

Shell
Omala S4 WE 320

Quantità olio per tutte
le posizioni: 1.20Lt.

Tab. 1

Tab. 2

347 Nm

Z85

PZ85UN.. Basic gearbox
Riduttore base

Gearbox weight
peso riduttore 13.00 kg

M. flanges	Kit code	øF	A
71B5	KZ234041	160	116.5
80/90B5	KZ234042	200	118.5
100/112B5	KZ234043	250	127.5
80B14	KZ854046	120	118.5
90B14	KZ854045	140	118.5
100/112B14	KZ854047	160	127.5

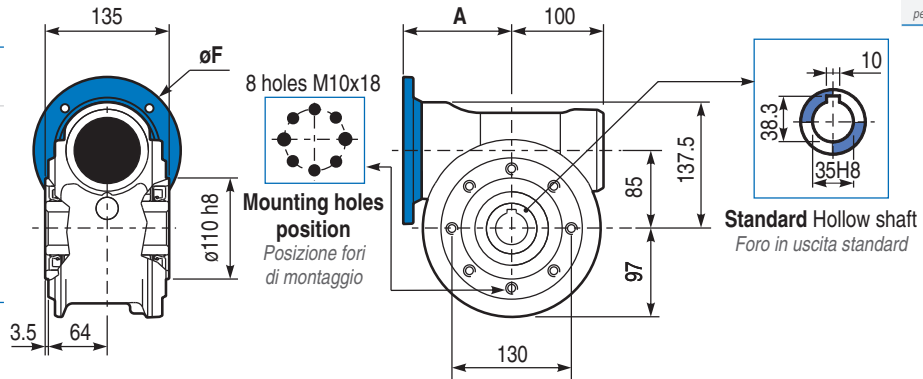

PZ85PA.. Feet
Piedini

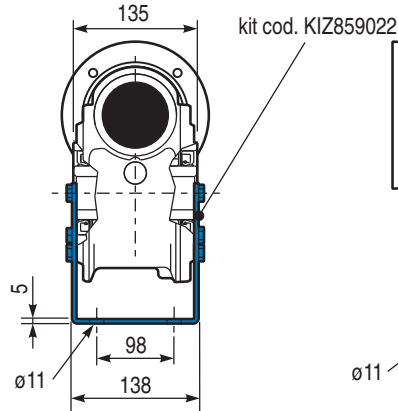

PZ85PV.. Feet
Piedini

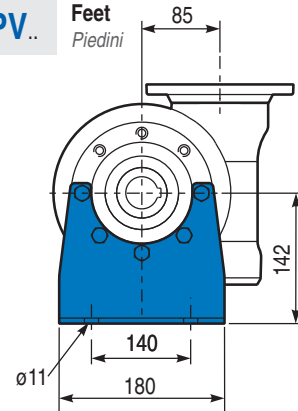

PZ85FC.. Output flange
Flangia uscita

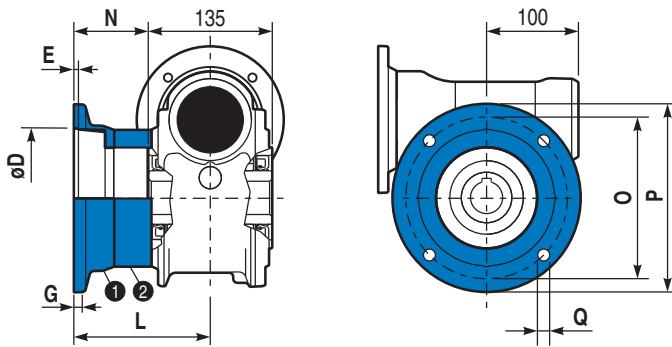

Type	øD	E	G	L	N	O	P	Q	Kit code
FC	152 ^{+0.06} / _{-0.00}	5	16	108	40.5	176	205	13	1 KZ859010 2 -
FL	152 ^{+0.06} / _{-0.00}	5	16	148.5	81	176	205	13	1 KZ859010 2 KZ850201

PZ85BR.. Reaction arm
Braccio di reazione

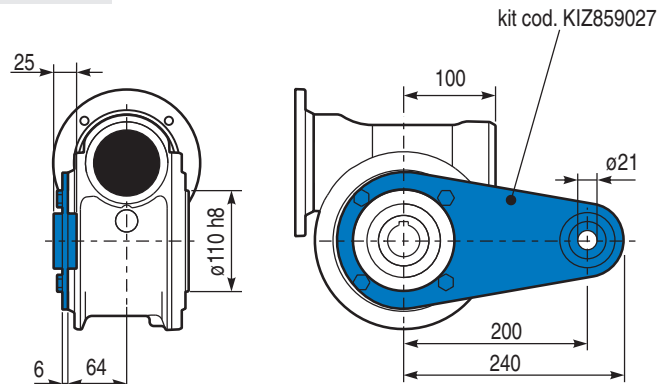

PZ85.S.. Single output shaft
Albero semplice in uscita

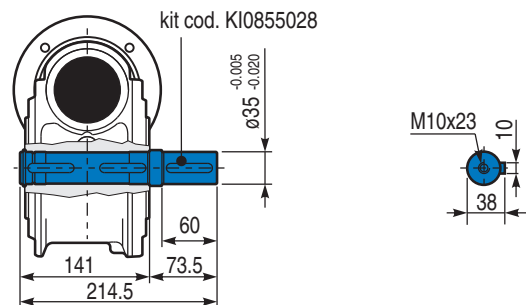

RZ85UN.. Input shaft
Albero in entrata

